

**ГОСУДАРСТВЕННЫЙ СТАНДАРТ СОЮЗА ССР****ПРОБКИ РЕЗЬБОВЫЕ  
С ПОЛНЫМ ПРОФИЛЕМ РЕЗЬБЫ  
ДИАМЕТРОМ от 52 до 100 мм****Конструкция и основные размеры**Threaded plug-gauges with full form  
of thread of diameters from 52 to 100 mm.  
Design and basic dimensions**ГОСТ  
17759—72**

ОКП 39 3141

Дата введения 01.07.73

1. Настоящий стандарт распространяется на калибры резьбовые для контроля метрической резьбы по ГОСТ 16093.

(Измененная редакция, Изм. № 2).

2. Конструкция и основные размеры пробок *ПР*, *У—ПР*, *КПР—ПР*, *У—НЕ*, *КНЕ—НЕ*, *КНЕ—ПР*, *КЙ—НЕ* должны соответствовать указанным на черт. 1 и в табл. 1.

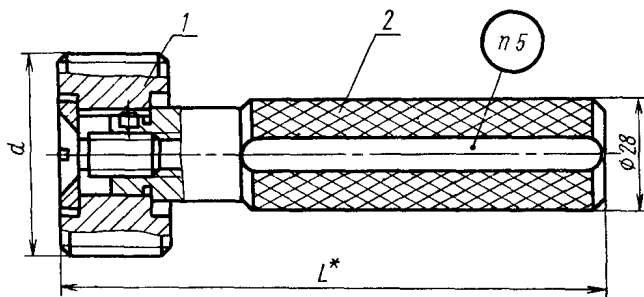

\* Размер для справок.

Черт. 1

## Размеры

		Обозначение			
Калибры		Контрольные			
ПР	У-ПР	КПР-ПР	У-НЕ	КНЕ-НЕ	КНЕ-ПР
8222-0159	8262-0159	8262-0301	8262-1159	8262-2159	8262-0396
8222-0160	8262-0160	8262-0302	8262-1160	8262-2160	8262-0397
8222-0161	8262-0161	8262-0303	8262-1161	8262-2161	8262-0398
8222-0162	8262-0162	8262-0304	8262-1162	8262-2162	8262-0399
8222-0163	8262-0163	8262-0305	8262-2163	8262-2163	8262-0400
8222-0164	8262-0164	8262-0306	8262-1164	8262-2164	8262-0401
8222-0165	8262-0165	8262-0307	8262-1165	8262-2165	8262-0402
8222-0166	8262-0166	8262-0308	8262-1166	8262-2166	8262-0403
8222-0167	8262-0167	8262-0309	8262-1167	8262-2167	8262-0404
8222-0168	8262-0168	8262-0310	8262-1168	8262-2168	8262-0405
8222-0169	8262-0169	8262-0311	8262-1169	8262-2169	8262-0406
8222-0170	8262-0170	8262-0312	8262-1170	8262-2170	8262-0407
8222-0171	8262-0171	8262-0313	8262-1171	8262-2171	8262-0408
8222-0172	8262-0172	8262-0314	8262-1172	8262-2172	8262-0409
8222-0173	8262-0173	8262-0315	8262-1173	8262-2173	8262-0410
8222-0174	8262-0174	8262-0316	8262-1174	8262-2174	8262-0411
8222-0175	8262-0175	8262-0317	8262-1175	8262-2175	8262-0412
8222-0176	8262-0176	8262-0318	8262-1176	8262-2176	8262-0413
8222-0177	8262-0177	8262-0319	8262-1177	8262-2177	8262-0414
8222-0178	8262-0178	8262-0320	8262-1178	8262-2178	8262-0415
8222-0179	8262-0179	8262-0321	8262-1179	8262-2179	8262-0416
8222-0180	8262-0180	8262-0322	8262-1180	8262-2180	8262-0417
8222-0181	8262-0181	8262-0323	8262-1181	8262-2181	8262-0418
8222-0182	8262-0182	8262-0324	8262-1182	8262-2182	8262-0419
8222-0183	8262-0183	8262-0325	8262-1183	8262-2183	8262-0420
8222-0184	8262-0184	8262-0326	8262-1184	8262-2184	8262-0421
8222-0185	8262-0185	8262-0327	8262-1185	8262-2185	8262-0422
8222-0186	8262-0186	8262-0328	8262-1186	8262-2186	8262-0423

Таблица 1

в мм

пробок	Применяемость						d	P	L		Масса, кг не более	Дет. 2 Ручка ГОСТ 14749		
	калибры	ПР	У-ПР	КПР-ПР	У-НЕ	КНЕ-НЕ			КНЕ-ПР	КИ-НЕ		ПР; У-ПР; КПР-ПР	У-НЕ; КНЕ-НЕ; КНЕ-ПР; КИ-НЕ	Дет. 1 Насадка 1 (шт.)
КИ-НЕ	ПР	У-ПР	КПР-ПР	У-НЕ	КНЕ-НЕ	КНЕ-ПР	КИ-НЕ					ПР У-ПР КПР-ПР (1 шт.)	У-НЕ КНЕ-НЕ КНЕ-ПР КИ-НЕ (1 шт.)	
Обозначение деталей														
8262-3159								5,0	157	140	0,96	0,71	8055-0027	8055-0025
8262-3160								4,0	151	135	0,90	0,65	8055-0027	8055-0023
8262-3161							52	3,0	143	135	0,75		8055-0025	8055-0023
8262-3162								2,0	137	133	0,65	0,61	8055-0024	8055-0023
8262-3163								1,5	135	133		0,61	8055-0023	8055-0023
8262-3164								1,0	133	133			8055-0023	8055-0023
8262-3165								4,0	151	135	0,96		8055-0027	8055-0023
8262-3166							55	3,0	143	135	0,80	0,65	8055-0025	8055-0023
8262-3167								2,0	137	133		0,71	8055-0024	8055-0023
8262-3168								1,5	135	133			8055-0023	8055-0023
8262-3169								5,5	165	143	1,23	0,82	8055-0028	8055-0025
8262-3170								4,0	151	135	0,98		8055-0027	8055-0023
8262-3171							56	3,0	143	135	0,82		8055-0025	8055-0023
8262-3172								2,0	137	133		0,67	8055-0024	8055-0023
8262-3173								1,5	135	133		0,71	8055-0023	8055-0023
8262-3174								1,0	133	133	0,64		8055-0023	8055-0023
8262-3175								4,0	151	135	1,03		8055-0027	8055-0023
8262-3176							58	3,0	143	135	0,86	0,71	8055-0025	8055-0023
8262-3177								2,0	137	133		0,75	8055-0024	8055-0023
8262-3178								1,5	135	133			8055-0023	8055-0023
8262-3179								5,5	165	143	1,37	0,90	8055-0028	8055-0025
8262-3180								4,0	151	135	1,08		8055-0027	8055-0023
8262-3 81								3,0	143	135	0,90		8055-0025	8055-0023
8262-3182							60	2,0	137	133		0,72	8055-0024	8055-0023
8262-3183								1,5	135	133		0,77	8055-0023	8055-0023
8262-3184								1,0	133	133	0,72		8055 0023	8055-0023
8262-3185								4 0	151	135	1,10		8055-0025	8055-0023
8262-3186							62	3,0	143	135	0,94	0,75	8055-0025	8055-0023

Обозначение дет. 1 см. табл. 2

## Размеры

Обозначение

Калибры		Контрольные			
<i>ПР</i>	<i>У-ПР</i>	<i>КПР-ПР</i>	<i>У-НЕ</i>	<i>КНЕ-НЕ</i>	<i>КНЕ-ПР</i>
8222-0187	8262-0187	8262-0329	8262-1187	8262-2187	8262-0424
8222-0188	8262-0188	8262-0330	8262-1188	8262-2188	8262-0425
8222-0189	8262-0189	8262-0331	8262-1189	8262-2189	8262-0426
8222-0190	8262-0190	8262-0332	8262-1190	8262-2190	8262-0427
8222-0191	8262-0191	8262-0333	8262-1191	8262-2191	8262-0428
8222-0192	8262 0192	8262-0334	8262-1192	8262-2192	8262-0429
8222 0193	8262-0193	8262-0335	8262-1193	8262-2193	8262-0430
8222-0194	8262-0194	8262-0336	8262-1194	8262-2194	8262-0431
8222-0195	8262-0195	8262-0337	8262-1195	8262-2195	8262-0432
8222-0196	8262-0196	8262-0338	8262-1196	8262 2196	8262-0433
8222-0197	8262-0197	8262-0339	8262-1197	8262-2197	8262-0434
8222-0198	8262-0198	8262-0340	8262-1198	8262-2198	8262-0435
8222-0199	8262-0199	8262-0341	8262-1199	8262-2199	8262-0436
8222-0200	8262-0200	8262-0342	8262-1200	8262-2200	8262-0437
8222-0201	8262-0201	8262-0343	8262-1201	8262-2201	8262-0438
8222-0202	8262-0202	8262-0344	8262-1202	8262 2202	8262 0439
8222-0203	8262-0203	8262-0345	8262-1203	8262-2203	8262-0440
8222-0204	8262-0204	8262-0346	8262-1204	8262-2204	8262-0441
8222-0205	8262-0205	8262-0347	8262-1205	8262-2205	8262-0442
8222-0206	8262-0206	8262-0348	8262-1206	8262-2206	8262-0443
8222-0207	8262-0207	8262-0349	8262-1207	8262-2207	8262-0444
8222-0208	8262 0208	8262-0350	8262-1208	8262-2208	8262-0445
8222-0209	8262-0209	8262-0351	8262-1209	8262-2209	8262-0446
8222-0210	8262-0210	8262-0352	8262-1210	8262-2210	8262-0447
8222-0211	8262-0211	8262-0353	8262-1211	8262-2211	8262-0448
8222-0212	8262-0212	8262-0354	8262-1212	8262-2212	8262-0449
8222-0213	8262-0213	8262-0355	8262-1213	8262-2213	8262-0450
8222-0214	8262-0214	8262-0356	8262-1214	8262-2214	8262-0451

В ММ

пробок	Применяемость						d	P	L		Масса, кг, не более	Дет. 2. Ручка ГОСТ 14749	
	калибры	ПР	У-ПР	КПР-ПР	У-НЕ	КНЕ-НЕ			КНЕ-ПР	КИ-НЕ		ПР; У-ПР; КПР-ПР	У-НЕ; КНЕ-НЕ; КНЕ-ПР; КИ-НЕ
КИ-НЕ												Обозначение деталей	
8262-3187						62	2,0	140	133	0,88	0,75	8055-0025	8055-0023
8262-3188							1,5	137	133			8055-0024	8055-0023
8262-3189							6,0	170	145	1,69	1,05	8055-0029	8055-0026
8262-3190							4,0	151	135	1,19		8055-0027	8055-0023
8262-3191						64	3,0	143	135	0,99		8055-0025	8055-0023
8262-3192							2,0	140	133		0,79	8055-0025	8055-0023
8262-3193							1,5	137	133		0,94	8055-0024	8055-0023
8262-3194							1,0	133	133		0,76	8055-0023	8055-0023
8262-3195							4,0	151	135	1,22		8055-0027	8055-0023
8262-3196						65	3,0	143	135		0,79	8055-0025	8055-0023
8262-3197							2,0	140	133		1,01	8055-0025	8055-0023
8262-3198							1,5	137	133		0,93	8055-0024	8055-0023
8262-3199							6,0	170	145	1,88	1,15	8055-0029	8055-0026
8262-3200							4,0	151	135	1,31		8055-0027	8055-0023
8262-3201						68	3,0	143	135		1,08	8055-0025	8055-0023
8262-3202							2,0	140	133		0,85	8055-0025	8055-0023
8262-3203							1,5	137	133		0,95	8055-0024	8055-0023
8262-3204							1,0	133	133		0,82	8055-0023	8055-0023
8262-3205							6,0	170	145	1,97	1,19	8055-0029	8055-0026
8262-3206							4,0	153	135	1,44		8055-0027	8055-0023
8262-3207						70	3,0	145	135	1,20	0,88	8055-0026	8055-0023
8262-3208							2,0	140	133			8055-0025	8055-0023
8262-3209							1,5	137	133		1,05	8055-0024	8055-0023
8262-3210							6,0	170	145	2,07	1,25	8055-0029	8055-0026
8262-3211							4,0	153	135	1,50		8055-0027	8055-0023
8262-3212							3,0	145	135	1,25		8055-0026	8055-0023
8262-3213						72	2,0	140	133		0,92	8055-0025	8055-0023
8262-3214							1,5	137	133		1,09	8055-0024	8055-0023

Обозначение дет. 1 см. табл. 2

## Размеры

		Обозначение			
Калибры	Контрольные				
ПР	У—ПР	КПР—ПР	У—НЕ	КНЕ—НЕ	КНЕ—ПР
8222-0215	8262-0215	8262-0357	8262-1215	8262-2215	8262-0452
8222-0216	8262-0216	8262-0358	8262-1216	8262-2216	8262-0453
8222-0217	8262-0217	8262-0359	8262-1217	8262-2217	8262-0454
8222-0218	8262-0218	8262-0360	8262-1218	8262-2218	8262-0455
8222-0219	8262-0219	8262-0361	8262-1219	8262-2219	8262-0456
8222-0220	8262-0220	8262-0362	8262-1220	8262-2220	8262-0457
8222-0221	8262-0221	8262-0363	8262-1221	8262-2221	8262-0458
8222-0222	8262-0222	8262-0364	8262-1222	8262-2222	8262-0459
8222-0223	8262-0223	8262-0365	8262-1223	8262-2223	8262-0460
8222-0224	8262-0224	8262-0366	8262-1224	8262-2224	8262-0461
8222-0225	8262-0225	8262-0367	8262-1225	8262-2225	8262-0462
8222-0226	8262-0226	8262-0368	8262-1226	8262-2226	8262-0463
8222-0227	8262-0227	8262-0369	8262-1227	8262-2227	8262-0464
8222-0228	8262-0228	8262-0370	8262-1228	8262-2228	8262-0465
8222-0229	8262-0229	8262-0371	8262-1229	8262-2229	8262-0466
8222-0230	8262-0230	8262-0372	8262-1230	8262-2230	8262-0467
8222-0231	8262-0231	8262-0373	8262-1231	8262-2231	8262-0468
8222-0232	8262-0232	8262-0374	8262-1232	8262-2232	8262-0469
8222-0233	8262-0233	8262-0375	8262-1233	8262-2233	8262-0470
8222-0234	8262-0234	8262-0376	8262-1234	8262-2234	8262-0471
8222-0235	8262-0235	8262-0377	8262-1235	8262-2235	8262-0472
8222-0236	8262-0236	8262-0378	8262-1236	8262-2236	8262-0473
8222-0237	8262-0237	8262-0379	8262-1237	8262-2237	8262-0474
8222-0238	8262-0238	8262-0380	8262-1238	8262-2238	8262-0475
8222-0239	8262-0239	8262-0381	8262-1239	8262-2239	8262-0476
8222-0240	8262-0240	8262-0382	8262-1240	8262-2240	8262-0477
8222-0241	8262-0241	8262-0383	8262-1241	8262-2241	8262-0478
8222-0242	8262-0242	8262-0384	8262-1242	8262-2242	8262-0479





## Размеры

Обозначение					
Калибры	Контрольные				
	<i>У—ПР</i>	<i>КПР—ПР</i>	<i>У—НЕ</i>	<i>КНЕ—НЕ</i>	<i>КНЕ—ПР</i>
<i>ПР</i>					
8222-0243	8262-0243	8262-0385	8262-1243	8262-2243	8262-0480
8222-0244	8262-0244	8262-0386	8262-1244	8262-2244	8262-0481
8222-0245	8262-0245	8262-0387	8262-1245	8262-2245	8262-0482
8222-0246	8262-0246	8262-0388	8262-1246	8262-2246	8262-0483
8222-0247	8262-0247	8262-0389	8262-1247	8262-2247	8262-0484
8222-0248	8262-0248	8262-0390	8262-1248	8262-2248	8262-0485
8222-0249	8262-0249	8262-0391	8262-1249	8262-2249	8262-0486
8222-0250	8262-0250	8262-0392	8262-1250	8262-2250	8262-0487
8222-0251	8262-0251	8262-0393	8262-1251	8262-2251	8262-0488
8222-0252	8262-0252	8262-0394	8262-1252	8262-2252	8262-0489
8222-0253	8262-0253	8262-0395	8262-1253	8262-2253	8262-0490

Пример условного обозначения пробки *ПР* для контроля резьбового отверстия с правой резьбой  $M56 \times 4$  с полем допуска 6H:

*Пробка 8222-0170 6H ГОСТ 17759—72*

То же, с левой резьбой:

*Пробка 8222-0170 6H LH ГОСТ 17759—72*

(Измененная редакция, Изм. № 1, 2, 3).

3. Конструкция и основные размеры насадок *ПР*, *У—ПР*, *КПР—ПР*, *У—НЕ*, *КНЕ—НЕ*, *КНЕ—ПР*, *КИ—НЕ* (деталь 1) должны соответствовать указанным на черт. 2 и в табл. 2.

Продолжение табл. 1

В ММ

пробок	Применяемость						L	Масса, кг, не более	Дет. 1. Насажка 1 (шт.)	Дет. 2 Ручка ГОСТ 14749				
	калибры	ПР	У-ПР	КПР-ПР	У-НЕ	КНЕ-НЕ				КНЕ-ПР	КИ-НЕ	ПР, У-ПР, КПР-ПР (1 шт.)	У-НЕ, КНЕ-НЕ; КНЕ-ПР; КИ-НЕ (1 шт.)	
КИ-НЕ	ПР	У-ПР	КПР-ПР	У-НЕ	КНЕ-НЕ	КНЕ-ПР	КИ-НЕ	ПР, У-ПР; КПР-ПР	У-НЕ, КНЕ-НЕ; КНЕ-ПР; КИ-НЕ	Обозначение деталей				
8262-3243							90	1,5	140	133	1,74	1,38	8055-0025	8055-0023
8262-3244							95	6,0	178	145	4,07	2,08	8055-0030	8055-0026
8262-3245								4,0	155	135	2,73		8055-0027	8055-0023
8262-3246							100	3,0	147	135	2,18	1,49	8055-0026	8055-0023
8262-3247								2,0	143	133			8055-0025	8055-0023
8262-3248							100	1,5	140	133	1,89		8055-0025	8055-0023
8262-3249								6,0	178	145	4,55	2,27	8055-0030	8055-0026
8262-3250							100	4,0	155	135	3,00		8055-0027	8055-0023
8262-3251								3,0	147	135	2,41		8055-0026	8055-0023
8262-3252							100	2,0	143	133		1,65	8055-0025	8055-0023
8262-3253								1,5	140	133	2,05		8055-0025	8055-0023

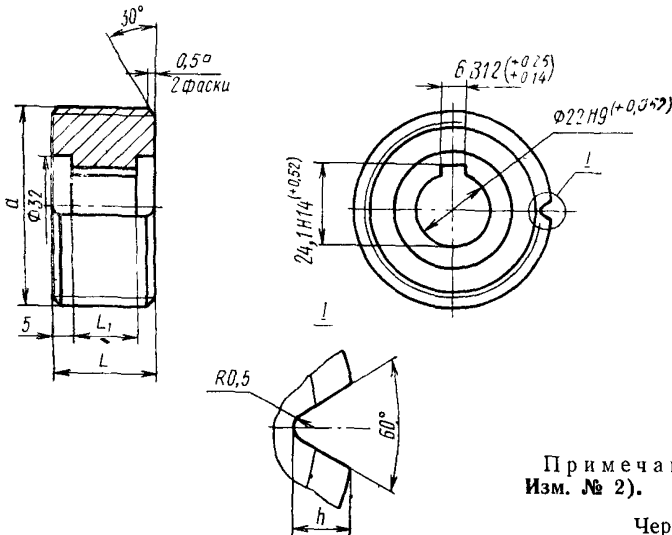

Примечание. (Исключено, Изм. № 2).

Черт. 2

## Размеры

Обозначение

ПР	У—ПР	КПР—ПР	У—НЕ	КНЕ—НЕ	КНЕ—ПР
8222-0159/1	8262-0159/1	8262-0301/1	8262-1159/1	8262-2159/1	8262-0396/1
8222-0160/1	8262-0160/1	8262-0302/1	8262-1160/1	8262-2160/1	8262-0397/1
8222-0161/1	8262-0161/1	8262-0303/1	8262-1161/1	8262-2161/1	8262-0398/1
8222-0162/1	8262-0162/1	8262-0304/1	8262-1162/1	8262-2162/1	8262-0399/1
8222-0163/1	<b>8262-0163/1</b>	<b>8262-0305/1</b>	8262-1163/1	8262-2163/1	<b>8262-0400/1</b>
8222-0164/1	<b>8262-0164/1</b>	8262-0306/1	8262-1164/1	8262-2164/1	8262-0401/1
8222-0165/1	8262-0165/1	8262-0307/1	8262-1165/1	8262-2165/1	8262-0402/1
8222-0166/1	8262-0166/1	8262-0308/1	8262-1166/1	8262-2166/1	8262-0403/1
8222-0167/1	8262-0167/1	<b>8262-0309/1</b>	8262-1167/1	8262-2167/1	8262-0404/1
8222-0168/1	8262-0168/1	8262-0310/1	8262-1168/1	8262-2168/1	8262-0405/1
8222-0169/1	<b>8262-0169/1</b>	8262-0311/1	8262-1169/1	8262-2169/1	8262-0406/1
8222-0170/1	8262-0170/1	8262-0312/1	8262-1170/1	8262-2170/1	8262-0407/1
8222-0171/1	8262-0171/1	8262-0313/1	8262-1171/1	8262-2171/1	8262-0408/1
8222-0172/1	8262-0172/1	8262-0314/1	8262-1172/1	8262-2172/1	8262-0409/1
8222-0173/1	8262-0173/1	8262-0315/1	8262-1173/1	8262-2173/1	8262-0410/1
8222-0174/1	8262-0174/1	8262-0316/1	8262-1174/1	8262-2174/1	8262-0411/1
8222-0175/1	8262-0175/1	8262-0317/1	8262-1175/1	8262-2175/1	8262-0412/1
8222-0176/1	8262-0176/1	8262-0318/1	8262-1176/1	8262-2176/1	8262-0413/1
8222-0177/1	8262-0177/1	8262-0319/1	8262-1177/1	8262-2177/1	8262-0414/1
8222-0178/1	8262-0178/1	8262-0320/1	8262-1178/1	8262-2178/1	8262-0415/1
8222-0179/1	8262-0179/1	8262-0321/1	8262-1179/1	8262-2179/1	8262-0416/1
8222-0180/1	8262-0180/1	8262-0322/1	8262-1180/1	8262-2180/1	8262-0417/1
8222-0181/1	8262-0181/1	8262-0323/1	8262-1181/1	8262-2181/1	8262-0418/1
8222-0182/1	8262-0182/1	8262-0324/1	8262-1182/1	8262-2182/1	8262-0419/1
8222-0183/1	8262-0183/1	8262-0325/1	8262-1183/1	8262-2183/1	8262-0420/1
8222-0184/1	8262-0184/1	8262-0326/1	8262-1184/1	8262-2184/1	8262-0421/1
8222-0185/1	8262-0185/1	8262-0327/1	8262-1185/1	8262-2185/1	8262-0422/1
8222-0186/1	8262-0186/1	8262-0328/1	8262-1186/1	8262-2186/1	8262-0423/1

Таблица 2

В мм

насадок  КИ—НЕ	d	P	L		L <sub>1</sub>		h	Масса, кг, не более	
			ПР: У—ПР; КПР—ПР	У—НЕ; КНЕ—НЕ; КНЕ—ПР; КИ—НЕ	ПР: У—ПР; КПР—ПР	У—НЕ; КНЕ—НЕ; КНЕ—ПР; КИ—НЕ		ПР: У—ПР; КПР—ПР	У—НЕ; КНЕ—НЕ; КНЕ—ПР; КИ—НЕ
8262-3159/1	52	5,0	42	25	32	15	5,0	0,55	0,33
8262-3160/1		4,0	36	20	26	10	4,0	0,49	0,29
8262-3161/1		2,0	28	20	18	10	3,0	0,37	0,25
8262-3162/1		2,0	22	18	12	8	2,0	0,28	
8262-3163/1		1,5	20	18	10	8	1,5	0,25	
8262-3164/1	1,0	18	18	8	8	1,0			
8262-3165/1	55	4,0	36	20	26	10	4,0	0,55	0,29
8262-3166/1		3,0	28	20	18	10	3,0	0,42	
8262-3167/1		2,0	22	18	12	8	2,0	0,34	
8262-3168/1		1,5	20	18	10	8	1,5		
8262-3169/1		5,5	50	28	40	18	5,5	0,80	0,44
8262-3170/1	56	4,0	36	20	26	10	4,0	0,57	0,31
8262-3171/1		3,0	28	20	18	10	3,0	0,44	
8262-3172/1		2,0	22	18	12	8	2,0	0,34	
8262-3173/1		1,5	20	18	10	8	1,5		
8262-3174/1		1,0	18	18	8	8	1,0	0,28	
8262-3175/1	58	4,0	36	20	26	10	4,0	0,62	0,35
8262-3176/1		3,0	28	20	18	10	3,0	0,48	
8262-3177/1		2,0	22	18	12	8	2,0	0,38	
8262-3178/1		1,5	20	18	10	8	1,5		
8262-3179/1		5,5	50	28	40	18	5,5	0,94	0,52
8262-3180/1	60	4,0	36	20	26	10	4,0	0,67	0,36
8262-3181/1		3,0	28	20	18	10	3,0	0,52	
8262-3182/1		2,0	22	18	12	8	2,0	0,40	
8262-3183/1		1,5	20	18	10	8	1,5		
8262-3184/1		1,0	18	18	8	8	1,0	0,36	
8262-3185/1	62	4,0	36	20	26	10	4,0	0,72	0,39
8262-3186/1		3,0	28	20	18	10	3,0	0,56	

Обозначение

ИР	У-ПР	КПР-ПР	У-НЕ	КНЕ-НЕ	КНЕ-ПР
8222-0187/1	8262-0187/1	8262-0329/1	8262-1187/1	8262-2187/1	8262-0424/1
8222-0188/1	8262-0188/1	8262-0330/1	8262-1188/1	8262-2188/1	8262-0425/1
8222-0189/1	8262-0189/1	8262-0331/1	8262-1189/1	8262-2189/1	8262-0426/1
8222-0190/1	8262-0190/1	8262-0332/1	8262-1190/1	8262-2190/1	8262-0427/1
8222-0191/1	8262-0191/1	8262-0333/1	8262-1191/1	8262-2191/1	8262-0428/1
8222-0192/1	8262-0192/1	8262-0334/1	8262-1192/1	8262-2192/1	8262-0429/1
8222-0193/1	8262-0193/1	8262-0335/1	8262-1193/3	8262-2193/1	8262-0430/1
8222-0194/1	8262-0194/1	8262-0336/1	8262-1194/1	8262-2194/1	8262-0431/1
8222-0195/1	8262-0195/1	8262-0337/1	8262-1195/1	8262-2195/1	8262-0432/1
8222-0196/1	8262-0196/1	8262-0338/1	8262-1196/1	8262-2196/1	8262-0433/1
8222-0197/1	8262-0197/1	8262-0339/1	8262-1197/1	8262-2197/1	8262-0434/1
8222-0198/1	8262-0198/1	8262-0340/1	8262-1198/1	8262-2198/1	8262-0435/1
8222-0199/1	8262-0199/1	8262-0341/1	8262-1199/1	8262-2199/1	8262-0436/1
8222-0200/1	8262-0200/1	8262-0342/1	8262-0200/1	8262-2200/1	8262-0437/1
8222-0201/1	8262-0201/1	8262-0343/1	8262-1201/1	8262-2201/1	8262-0438/1
8222-0202/1	8262-0202/1	8262-0344/1	8262-1202/1	8262-2202/1	8262-0439/1
8222-0203/1	8262-0203/1	8262-0345/1	8262-1203/1	8262-2203/1	8262-0440/1
8222-0204/1	8262-0204/1	8262-0346/1	8262-1204/1	8262-2204/1	8262-0441/1
8222-0205/1	8262-0205/1	8262-0347/1	8262-1205/1	8262-2205/1	8262-0442/1
8222-0206/1	8262-0206/1	8262-0348/1	8262-1206/1	8262-2206/1	8262-0443/1
8222-0207/1	8262-0207/1	8262-0349/1	8262-1207/1	8262-2207/1	8262-0444/1
8222-0208/1	8262-0208/1	8262-0350/1	8262-1208/1	8262-2208/1	8262-0445/1
8222-0209/1	8262-0209/1	8262-0351/1	8262-1209/1	8262-2209/1	8262-0446/1
8222-0210/1	8262-0210/1	8262-0352/1	8262-1210/1	8262-2210/1	8262-0447/1
8222-0211/1	8262-0211/1	8262-0353/1	8262-1211/1	8262-2211/1	8262-0448/1
8222-0212/1	8262-0212/1	8262-0354/1	8262-1212/1	8262-2212/1	8262-0449/1
8222-0213/1	8262-0213/1	8262-0355/1	8262-1213/1	8262-2213/1	8262-0450/1
8222-0214/1	8262-0214/1	8262-0356/1	8262-1214/1	8262-2214/1	8262-0451/1

Продолжение табл. 2

В мм

насадок	d	p	L		L <sub>1</sub>		h	Масса, кг, не более	
			ПР; У—ПР; КПР—ПР	У—НЕ; КНЕ—НЕ; КНЕ—ПР; КИ—НЕ	ПР; У—ПР; КПР—ПР	У—НЕ; КНЕ—НЕ; КНЕ—ПР; КИ—НЕ		ПР	ПР; У—ПР; КПР—ПР
КИ—НЕ									
8262-3187/1	62	2,0	25	18	15	8	2,0	0,50	0,39
8262-3188/1		1,5	22	18	12	8	1,5		
8262-3189/1	64	6,0	56	30	46	20	5,0	1,23	0,65
8262-3190/1		4,0	36	20	26	10	4,0		
8262-3191/1		3,0	28	20	18	10	3,0		
8262-3192/1		2,0	25	18	15	8	2,0		
8262-3193/1		1,5	22	18	12	8	1,5		
8262-3194/1		1,0	18	18	8	8	1,0		
8262-3195/1	65	4,0	36	20	26	10	4,0	0,81	0,43
8262-3196/1		3,0	28	20	18	10	3,0		
8262-3197/1		2,0	25	18	15	8	2,0		
8262-3198/1		1,5	22	18	12	8	1,5		
8262-3199/1	68	6,0	56	30	46	20	6,0	1,42	0,75
8262-3200/1		4,0	36	20	26	10	4,0		
8262-3201/1		3,0	28	20	18	10	3,0		
8262-3202/1		2,0	25	18	15	8	2,0		
8262-3203/1		1,5	22	18	12	8	1,5		
8262-3204/1		1,0	18	18	8	8	1,0		
8262-3205/1		6,0	56	30	46	20	6,0		
8262-3206/1		4,0	38	20	28	10	4,0		
8262-3207/1	70	3,0	30	20	20	10	3,0	0,80	0,52
8262-3208/1		2,0	25	18	15	8	2,0		
8262-3209/1		1,5	22	18	12	8	1,5		
8262-3210/1	72	6,0	56	30	46	20	6,0	1,61	0,85
8262-3211/1		4,0	38	20	28	10	4,0		
8262-3212/1		3,0	30	20	20	10	3,0		
8262-3213/1		2,0	25	18	15	8	2,0		
8262-3214/1		1,5	22	18	12	8	1,5		

Обозначение

ПР	У-ПР	КПР-ПР	У-НЕ	КНЕ-НЕ	КНЕ-ПР
8222-0215/1	8262-0215/1	8262-0357/1	8262-1215/1	8262-2215/1	8262-0452/1
8222-0216/1	8262-0216/1	8262-0358/1	8262-1216/1	8262-2216/1	8262-0453/1
8222-0217/1	8262-0217/1	8262-0359/1	8262-1217/1	8262-2217/1	8262-0454/1
8222-0218/1	8262-0218/1	8262-0360/1	8262-1218/1	8262-2218/1	8262-0455/1
8222-0219/1	8262-0219/1	8262-0361/1	8262-1219/1	8262-2219/1	8262-0456/1
8222-0220/1	8262-0220/1	8262-0362/1	8262-1220/1	8262-2220/1	8262-0457/1
8222-0221/1	8262-0221/1	8262-0363/1	8262-1221/1	8262-2221/1	8262-0458/1
8222-0222/1	8262-0222/1	8262-0364/1	8262-1222/1	8262-2222/1	8262-0459/1
8222-0223/1	8262-0223/1	8262-0365/1	8262-1223/1	8262-2223/1	8262-0460/1
8222-0224/1	8262-0224/1	8262-0366/1	8262-1224/1	8262-2224/1	8262-0461/1
8222-0225/1	8262-0225/1	8262-0367/1	8262-1225/1	8262-2225/1	8262-0462/1
8222-0226/1	8262-0226/1	8262-0368/1	8262-1226/1	8262-2226/1	8262-0463/1
8222-0227/1	8262-0227/1	8262-0369/1	8262-1227/1	8262-2227/1	8262-0464/1
8222-0228/1	8262-0228/1	8262-0370/1	8262-1228/1	8262-2228/1	8262-0465/1
8222-0229/1	8262-0229/1	8262-0371/1	8262-1229/1	8262-2229/1	8262-0466/1
8222-0230/1	8262-0230/1	8262-0372/1	8262-1230/1	8262-2230/1	8262-0467/1
8222-0231/1	8262-0231/1	8262-0373/1	8262-1231/1	8262-2231/1	8262-0468/1
8222-0232/1	8262-0232/1	8262-0374/1	8262-1232/1	8262-2232/1	8262-0469/1
8222-0233/1	8262-0233/1	8262-0375/1	8262-1233/1	8262-2233/1	8262-0470/1
8222-0234/1	8262-0234/1	8262-0376/1	8262-1234/1	8262-2234/1	8262-0471/1
8222-0235/1	8262-0235/1	8262-0377/1	8262-1235/1	8262-2235/1	8262-0472/1
8222-0236/1	8262-0236/1	8262-0378/1	8262-1236/1	8262-2236/1	8262-0473/1
8222-0237/1	8262-0237/1	8262-0379/1	8262-1237/1	8262-2237/1	8262-0474/1

в мм

насадок  КИ—НЕ	d	P	L		L <sub>1</sub>		h	Масса, кг, не более	
			ПР; У—ПР; КПР—ПР	У—НЕ; КНЕ—НЕ; КНЕ—ПР; КИ—НЕ	ПР; У—ПР; КПР—ПР	У—НЕ; КНЕ—НЕ; КНЕ—ПР; КИ—НЕ		ПР; У—ПР; КПР—ПР	У—НЕ; КНЕ—НЕ; КНЕ—ПР; КИ—НЕ
8262-3215/1	72	1,0	20	18	10	8	1,0	0,58	0,56
8262-3216/1	75	4,0	38	20	28	10	4,0	1,27	0,66
8262-3217/1		3,0	30	20	20	10	3,0	0,98	
8262-3218/1		2,0	25	18	15	8	2,0	0,79	
8262-3219/1		1,5	22	18	12	8	1,5		
8262-3220/1		6,0	56	30	46	20	6,0	1,81	
8262-3221/1	76	4,0	38	20	28	10	4,0	1,32	0,69
8262-3222/1		3,0	30	20	20	10	3,0	0,96	
8262-3223/1		2,0	25	18	15	8	2,0	0,80	
8262-3224/1		1,5	22	18	12	8	1,5		
8262-3225/1		1,0	20	18	10	8	1,0	0,66	
8262-3226/1	78	2,0	25	18	15	8	2,0	0,87	1,08
8262-3227/1	80	6,0	56	30	46	20	6,0	2,14	
8262-3228/1		4,0	38	20	28	10	4,0	1,52	
8262-3229/1		3,0	30	20	20	10	3,0	1,15	
8262-3230/1	82	2,0	25	18	15	8	2,0	0,90	0,75
8262-3231/1		1,5	22	18	12	8	1,5		
8262-3232/1		1,0	20	18	10	8	1,0	0,75	
8262-3233/1	85	2,0	25	18	15	8	2,0	0,95	1,28
8262-3234/1		6,0	56	30	46	20	6,0	2,45	
8262-3235/1		4,0	38	20	28	10	4,0	1,72	
8262-3236/1		3,0	30	20	20	10	3,0	1,27	
8262-3237/1		2,0	25	18	15	8	2,0	1,06	0,88



ПР	У-ПР	КПР- ПР	У-НЛ	КНЛ-НЛ	КНЛ-ПР
8222-0238/1	8262-0238/1	8262-0380/1	8262-1238/1	8262-2238/1	8262-0475/1
8222-0239/1	8262-0239/1	8262-0381/1	8262-1239/1	8262-2239/1	8262-0476/1
8222-0240/1	8262-0240/1	8262-0382/1	8262-1240/1	8262-2240/1	8262-0477/1
8222-0241/1	8262-0241/1	8262-0383/1	8262-1241/1	8262-2241/1	8262-0478/1
8222-0242/1	8262-0242/1	8262-0384/1	8262-1242/1	8262-2242/1	8262-0479/1
8222-0243/1	8262-0243/1	8262-0385/1	8262-1243/1	8262-2243/1	8262-0480/1
8222-0244/1	8262-0244/1	8262-0386/1	8262-1244/1	8262-2244/1	8262-0481/1
8222-0245/1	8262-0245/1	8262-0387/1	8262-1245/1	8262-2245/1	8262-0482/1
8222-0246/1	8262-0246/1	8262-0388/1	8262-1246/1	8262-2246/1	8262-0483/1
8222-0247/1	8262-0247/1	8262-0389/1	8262-1247/1	8262-2247/1	8262-0484/1
8222-0248/1	8262-0248/1	8262-0390/1	8262-1248/1	8262-2248/1	8262-0485/1
8222-0249/1	8262-0249/1	8262-0391/1	8262-1249/1	8262-2249/1	8262-0486/1
8222-0250/1	8262-0250/1	8262-0392/1	8262-1250/1	8262-2250/1	8262-0487/1
8222-0251/1	8262-0251/1	8262-0393/1	8262-1251/1	8262-2251/1	8262-0488/1
8222-0252/1	8262-0252/1	8262-0394/1	8262-1252/1	8262-2252/1	8262-0489/1
8222-0253/1	8262-0253/1	8262-0395/1	8262-1253/1	8262-2253/1	8262-0490/1

В ММ

насадок	<i>d</i>	<i>P</i>	<i>L</i>		<i>L</i> <sub>1</sub>		<i>h</i>	Масса, кг, ис более	
			ПР; У-ПР; КПР-ПР	У-НЕ; КНЕ-НЕ; КНЕ-ПР; КИ-НЕ	ПР; У-ПР; КПР-ПР	У-НЕ; КНЕ-НЕ; КНЕ-ПР; КИ-НЕ		ПР; У-ПР; КПР-ПР	У-НЕ; КНЕ-НЕ; КНЕ-ПР; КИ-НЕ
8262-3238/1	85	1,5	22	18	12	8	1,5	1,06	0,88
8262-3239/1		6,0	60	30	50	20	6,0	3,01	1,48
8262-3240/1	90	4,0	40	20	30	10	4,0	2,06	1,02
8262-3241/1		3,0	32	20	22	10	3,0	1,60	
8262-3242/1		2,0	28	18	18	8	2,0	1,36	
8262-3243/1		1,5	25	18	15	8	1,5		
8262-3244/1		6,0	63	30	53	20	6,0	3,52	
8262-3245/1	95	4,0	40	20	30	10	4,0	2,32	1,13
8262-3246/1		3,0	32	20	22	10	3,0	1,78	
8262-3247/1		2,0	28	18	18	8	2,0	1,51	
8262-3248/1		1,5	25	18	15	8	1,5		
8262-3249/1		6,0	63	30	53	20	6,0	4,00	
8262-3250/1	100	4,0	40	20	30	10	4,0	2,59	1,29
8262-3251/1		3,0	32	20	22	10	3,0	2,01	
8262-3252/1		2,0	28	18	18	8	2,0		
8262-3253/1		1,5	25	18	15	8	1,5	1,67.	

Пример условного обозначения проходной насадки ПР для контроля резьбового отверстия с правой резьбой М56×4 с полем допуска 6Н:

*Насадка 8222-0170/1 6Н ГОСТ 17759—72*

То же, с левой резьбой:

*Насадка 8222-0170/1 6Н ЛН ГОСТ 17759—72*

**(Измененная редакция, Изм. № 2, 3).**

3а. Исполнительные размеры — по ГОСТ 18465 и ГОСТ 18466.

**(Введен дополнительно, Изм. № 2).**

4. Технические требования — по ГОСТ 2016.

5. Маркировать по ГОСТ 2016 с добавлением последних четырех знаков обозначения на калибрах.

## ИНФОРМАЦИОННЫЕ ДАННЫЕ

**1. РАЗРАБОТАН И ВНЕСЕН** Министерством станкостроительной и инструментальной промышленности СССР

### РАЗРАБОТЧИКИ

И. А. Медовой, Г. С. Кудинова

**2. УТВЕРЖДЕН И ВВЕДЕН В ДЕЙСТВИЕ** Постановлением Государственного комитета СССР по стандартам от 30.05.72 № 1101

**3. Срок проверки — 1994 г.,**  
периодичность проверки — 10 лет

**4. ВЗАМЕН** МН 567—62

**5. ССЫЛОЧНЫЕ НОРМАТИВНО-ТЕХНИЧЕСКИЕ ДОКУМЕНТЫ**

Обозначение НТД, на который дана ссылка	Номер пункта
ГОСТ 2016—86	4, 5
ГОСТ 14749—69	2
ГОСТ 16093—81	1
ГОСТ 18465—73	3а
ГОСТ 18466—73	3а

**6. ПЕРЕИЗДАНИЕ** (март 1990 г.) с Изменениями № 1, 2, 3, утвержденными в сентябре 1974 г., ноябре 1983 г., июле 1989 г. (ИУС 10—74, 2—84, 12—89).